



Air vent systems

Thermal regulation



vent_006_a_1_cat

Air vents

The solution for

- > Automation equipment
- > Power distribution



Strong points

- > Quick mounting
- > Easy connections
- > Reversible flow of air vents
- > Degree of protection: IP54 - IP55 (optional)

Conformity to standards

- > Extraction using fans as per standard IEC 44.5
- > ABS UL94 V0 self-extinguishable

Available on request

- > Special paint
- > Other voltages
- > Other degree of protection

Function

SOCOMECAir vent systems ensure an homogeneous temperature is maintained between the inside of the cabinet and the surrounding premises.

19" fan trays improve the air flow in the enclosures and avoid heat accumulation.

Advantages

Rapid mounting and connection

Characteristics of the roof mounted extraction module

- Natural extraction with and without fan.
- Sheet metal enclosure - colour RAL7035.
- Fan mounted on foam tape with built-in thermal protection.
- 3 meter power supply cable.
- Self adhesive seal.

Characteristics of the 19" fan tray

- 3 models.
- Easy connection via a power supply plug at the rear.
- Front panel in anodised aluminium - zinc coated sheet metal case.
- Bearing ball mounted fans.
- Attached to the 19" structure screws.

Characteristics of the air vent

- 8 models from 35 to 990 m³/h.
- Fans with sealing foam tape on the bottom of the cabinet.
- Power supply voltage 230 V in 50/60 Hz.
- Clip fixing.
- Extraction from the top.

References

Air vent

Air flow with free blowing Air vent	35 m ³ /h Reference	67 m ³ /h Reference	108 m ³ /h Reference	190 m ³ /h Reference
Air vent and filter	5199 9010	5199 9012	5199 9017	5199 9023
Air vent and filter with aspirator fan, reversible to extractor fan	5199 9110	5199 9112	5199 9117	5199 9123
Spare filter: kit of 10 units	5199 9210	5199 9212	5199 9217	5199 9223

Air flow with free blowing Air vent	270 m ³ /h Reference	500 m ³ /h Reference	700 m ³ /h Reference	850 m ³ /h Reference
Air vent and filter	5199 9023	5199 9029	5199 9029	5199 9029
Air vent and filter with aspirator fan, reversible to extractor fan	5199 9124	5199 9129	5199 9130	5199 9131
Spare filter: kit of 10 units	5199 9223	5199 9229	5199 9229	5199 9229

Roof mounted extraction module

Air flow with free blowing Extraction module	575 m ³ /h Reference	860 m ³ /h Reference	1450 m ³ /h Reference	2365 m ³ /h Reference
Natural	5199 5001	-	5199 5003	-
With fan	5199 5055	5199 5090	5199 5150	5199 5280

Number of air inlet vents Number of air inlet vents	575 m ³ /h Reference	860 m ³ /h Reference	1450 m ³ /h Reference	2365 m ³ /h Reference
1	5199 9023	5199 9029	-	-
2	-	-	5199 9029	-
6	-	-	-	5199 9029

19" fan tray

Air flow with free blowing Number of fans per tray	466 m ³ /h Reference	972 m ³ /h Reference	1456 m ³ /h Reference
3	5199 8003	-	-
6	-	5199 8006	-
9	-	-	5199 8009

Characteristics

Air vent

Air flow with free blowing	35 m ³ /h	67 m ³ /h	108 m ³ /h	190 m ³ /h	270 m ³ /h	500 m ³ /h	700 m ³ /h	850 m ³ /h
Air vent - H x W x D (mm)	119 x 119 x 28,5	152 x 152 x 32,5	204 x 204 x 33,5	250 x 250 x 47,5	250 x 250 x 47,5	318 x 318 x 34	318 x 318 x 34	318 x 318 x 34
Air vent and fan - H x W x D (mm)	119 x 119 x 57,5	152 x 152 x 75	204 x 204 x 98	250 x 250 x 118	250 x 250 x 99	318 x 318 x 139	318 x 318 x 135	318 x 318 x 160,5
Air flow with one air vent of same dimension (m ³ /h)	24	50	75	130	200	380	600	590
Air flow with one air vent of larger dimension (m ³ /h)	27	58	88	160	220	450	-	-
Power-supply voltage (VAC)	230	230	230	230	230	230	230	230
Frequency (Hz)	50 / 60	50 / 60	50 / 60	50 / 60	50 / 60	50 / 60	50 / 60	50 / 60
Power (W) / Rating (A)	4,6 / 0,21	22 / 0,14	22 / 0,14	39 / 0,28	50 / 0,26	50 / 0,26	115 / 0,51	142 / 0,63
Sound level (dBA)	33	49	49	54	62	62	68	71
Operating temperature (°C)	-10 ... +70	-10 ... +70	-10 ... +70	-10 ... +70	-10 ... +60	-10 ... +60	-25 ... +55	-25 ... +55
Indice de protection / Nema	54 / 12	54 / 12	54 / 12	54 / 12	54 / 12	54 / 12	54 / 12	54 / 12

Roof mounted extraction module

Air flow with free blowing	575 m ³ /h	860 m ³ /h	1450 m ³ /h	2365 m ³ /h
Air vent (nb/dimension)	1 / 250 x 250	1 / 325 x 325	2 / 325 x 325	6 / 325 x 325
Air flow with one air vent (m ³ /h)	390	600	1100	2100
Power-supply voltage (VAC)	230	230	230	230
Frequency (Hz)	50 / 60	50 / 60	50/60 Hz	50/60 Hz
Absorbed power (W)	80	85	155	170
Sound level (dBA)	62	70	76	77
Operating temperature limits (evacuated air) (°C)	-20 ... +55	-20 ... +55	-20 ... +55	-20 ... +55

19" fan tray

Air flow with free blowing	466 m ³ /h	972 m ³ /h	1456 m ³ /h
Power-supply voltage (VAC)	230	230	230
Frequency (Hz)	50	50	50
Absorbed power (W)	49	90	135
Operating temperature (°C)	-20 ... +70	-20 ... +70	-20 ... +70

Dimensions

35 m³/h

Air vent

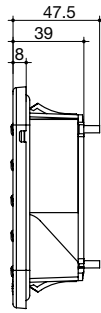
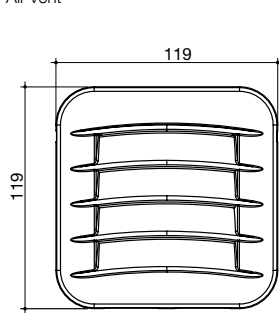

Fan

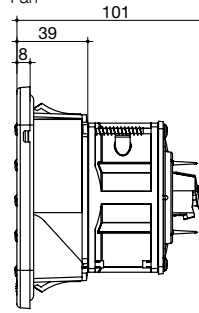

Cutout

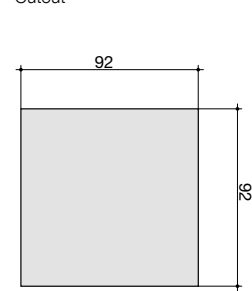

venti_037_a_1_x_cat

67 m³/h

Air vent

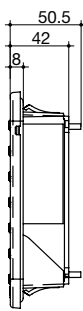
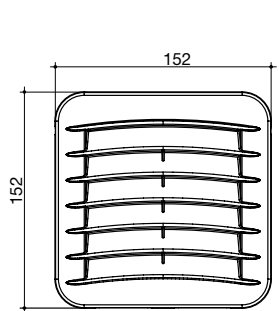

Fan

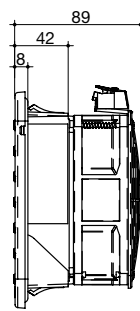

Cutout

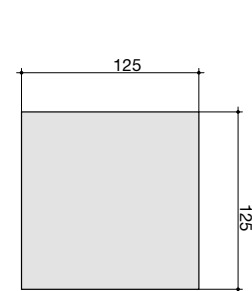

venti_038_a_1_x_cat

108 m³/h

Air vent

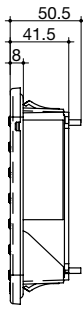
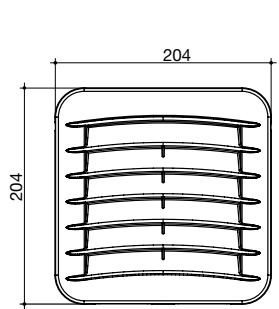

Fan

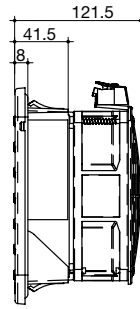

Cutout

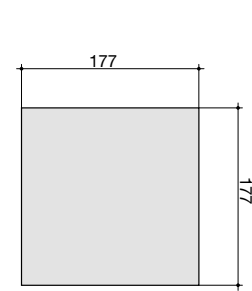

venti_039_a_1_x_cat

190 m³/h

Air vent

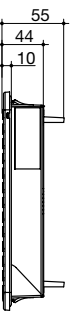
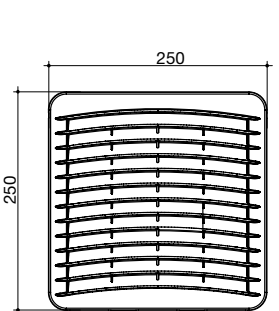

Fan

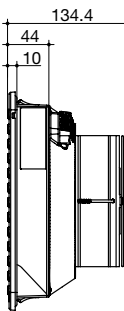

Cutout

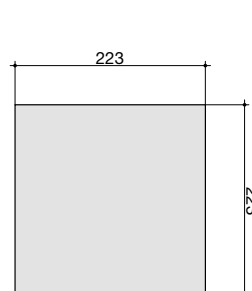

venti_040_a_1_x_cat

370 m³/h

Air vent

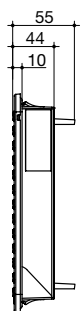
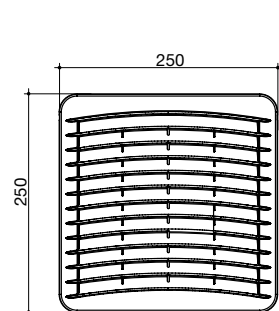

Fan

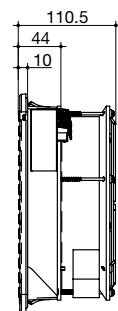

Cutout

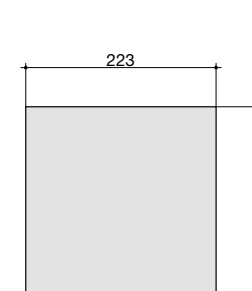

venti_041_a_1_x_cat

Dimensions (continued)

500 m^{3/h}

Air vent

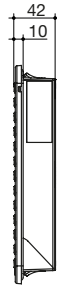
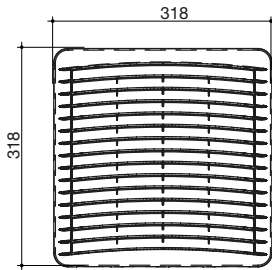

Fan

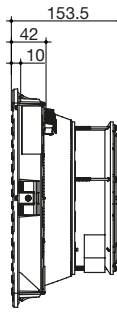

Cutout

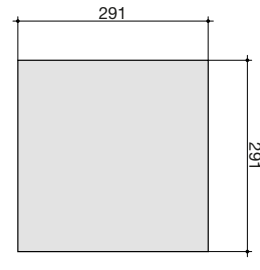

venti_042_a_1_x_cat

615 m^{3/h}

Air vent

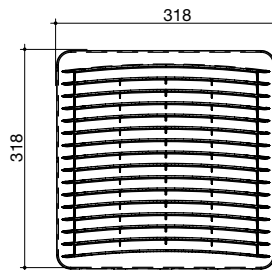

Fan

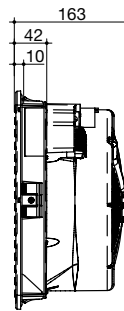

Cutout

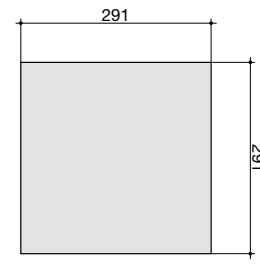

venti_043_a_1_x_cat

990 m^{3/h}

Air vent

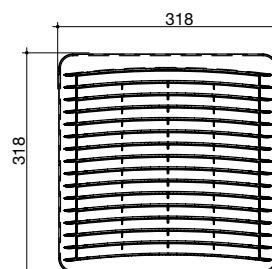

Fan

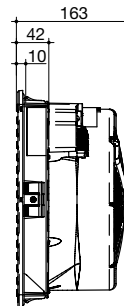

Cutout

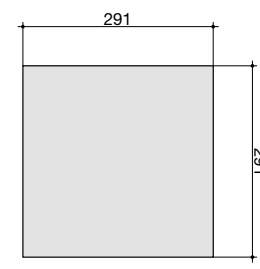

venti_043_a_1_x_cat

Roof mounted extraction module

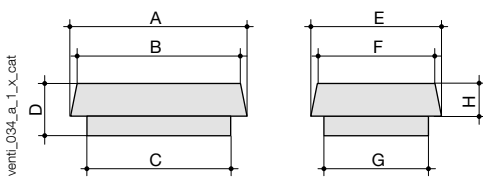

Flow (m ³ /h)	A	B	C	D	E	F	G	H
575 - 860	460	420	380	108	380	340	300	60
1450	540	500	440	160	400	390	320	100
2365	600	540	480	265	550	490	470	190

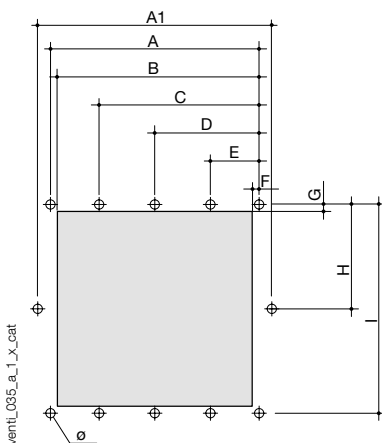

Flow (m ³ /h)	A ₁	A	B	C	D	E	F	G	H	I	Ø (mm)
575 - 860	360	350	305		55	10	10	140	280		6
1450	410	410	405	275	135	10	15	145	290		6
2365	450	450	435	345	225	105	15	15	215	415	6

19" fan tray

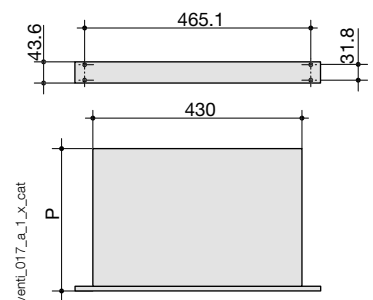

Number of fans per tray	P (mm)
3	208
6	330
9	452