



# RESYS M40R

Type A earth leakage relays  
with automatic reclosing

Electronic  
protection



resys\_082\_a\_1\_cat

## The solution for

- > Power distribution (Public lighting)
- > Water treatment
- > Processes
- > Telecom, Datacom and broadcasting
- > Farm buildings

## Strong points

- > Automatic reclosing
- > Fully configurable
- > Continuity of the power supply for strategic applications
- > Tripping accuracy by TRMS measurement
- > Instantaneous display of permanent leakage currents

## Conformity to standards

- > IEC 60755
- > IEC 60947-2
- > IEC 60664
- > IEC 61543 A1



## Function

RESYS M40R earth leakage relays associated with a remote trip breaking device (automatic power breaking and reclosing), provide the following functions:

- protection against indirect contact,
- limitation of leakage currents.
- reclosing of trip breaking device after earth leakage detection and power supply breaking.

The relay recloses the system up to six consecutive times after different time intervals. If the fault is still present after the sequence of six reclosing attempts, the relay is locked in alarm mode and a manual intervention will be required.

Rapid recognition of an insulation fault increases the availability of the distribution network by preventing accidental power cuts and the resulting loss of production. TRMS measurement avoids repeated random tripping and the bargraph allows the display of permanent leakage current.

## Advantages

### Automatic reclosing

This function provides protection, particularly in isolated sites or for processes requiring a restart in the event of transient faults (continuity of service ensured in the absence of a maintenance team).

### Fully configurable

- Adjustment of  $I_{\Delta n}$  from 0.03 to 30 A.
- Time delay 0 to 10 s.

### Ensures continuity of the power supply for strategic applications or in isolated sites

In the majority of cases, where the fault is not permanent, simply reclosing may resolve the situation.

### Tripping accuracy by TRMS measurement

Improves immunity to nuisance tripping.

### Instantaneous display of permanent leakage currents

The LED bargraph provides a real-time display of fluctuations in leakage currents.

## Applications

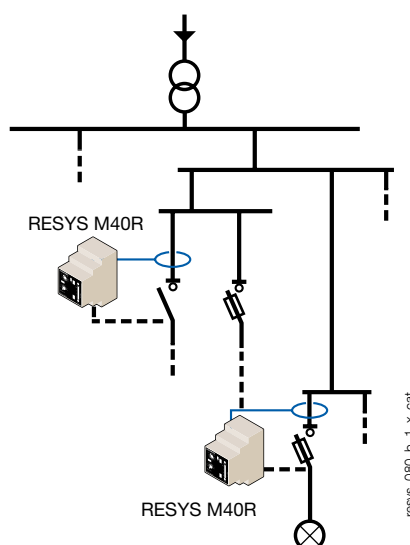

resys\_080\_b\_1\_X\_cat

The RESYS M40R relay must be combined with an automatic tripping/reclosing breaking device:

- a motorised switch
- a device fitted with an undervoltage coil
- a contactor.

## Front panel

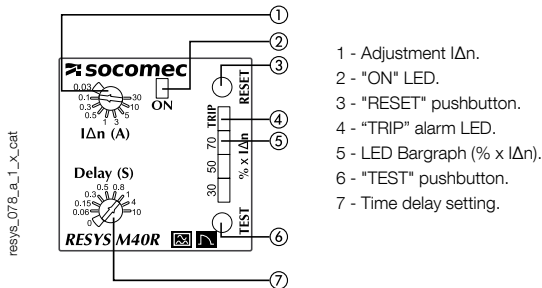

- 1 - Adjustment  $I_{\Delta n}$ .
- 2 - "ON" LED.
- 3 - "RESET" pushbutton.
- 4 - "TRIP" alarm LED.
- 5 - LED Bargraph (%  $\times I_{\Delta n}$ ).
- 6 - "TEST" pushbutton.
- 7 - Time delay setting.

## Case

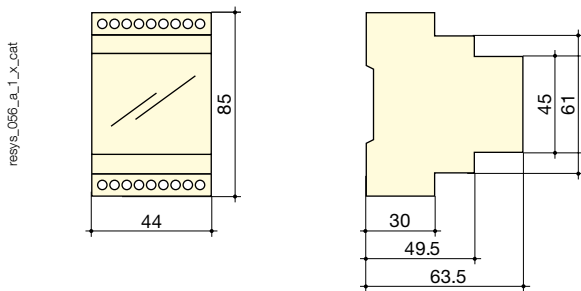

Type	modular
Number of modules	2.5
Dimensions W x H x D	44 x 85 x 63.5 mm
Case protection index	IP40
Terminal protection index	IP20
Rigid cable cross-section	0.2 ... 4 mm <sup>2</sup>
Flexible cable cross-section	0.2 ... 2.5 mm <sup>2</sup>
Weight	190 g

## Characteristics

### Auxiliary power supply $U_s$

Frequency	47 ... 63 Hz
AC operating zone	0.8 ... 1.15 $U_s$
DC operating zone	0.8 ... 1.05 $U_s$
Max. consumption	6 VA (AC) / 5 W (DC)

### Insulation (according to IEC 60664-1 standard)

Rated insulation voltage	250 VAC
Rated impulse voltage	2.5 kV (115 VAC) / 4 kV (230/400 VAC)
Degree of pollution	Class 3

### Threshold values

$I_{\Delta n}$ setting	0.03 - 0.1 - 0.3 - 0.5 - 1 - 3 - 5 - 10 - 30 A
Accuracy of tripping	- 20 ... - 10 % $I_{\Delta n}$
Domain of mains frequency	15 ... 400 Hz
Time delay setting	0 - 0.06 - 0.15 - 0.30 - 0.50 - 0.80 - 1 - 4 - 10 s

### Reclosing

Nb of automatic reclosing attempts	6 max
Time delay between two reclosing	7.5 - 15 - 30 - 60 - 120 - 240 s
Reset of automatic reclosing counter ( $t_{CR}$ )	15 min

### Alarm

Alarm configuration mode	automatic reset (6x max, then recording)
Reset	manual by pushbutton / using terminal

### Output contacts

Number of contacts	2
Type of ALARM 1 contact	inverter
Type of ALARM 2 contact	simple
Characteristics contact ALARM 1	250 VAC - 8 A - 2000 VA
Characteristics contact ALARM 2	250 VAC - 6 A - 1500 VA
ALARM 1 operating mode	negative security <sup>(1)</sup>
ALARM 2 operating mode	positive security <sup>(1)</sup>

(1) Negative security: relay activated in case of alarm /  
Positive security: relay not activated in case of alarm.

### Operating conditions

Operating temperature	- 20 ... + 55 °C
Storage temperature	- 30 ... + 70 °C

## Terminals and connections

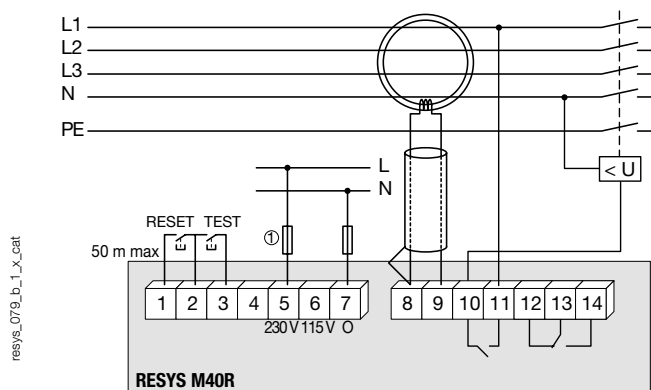

- 1 - 2 - 3: external push buttons
- 5 - 6 - 7: auxiliary power supplies  $U_s$
- 8 - 9: SOCOMEC differential toroid connections
- 10 - 11: alarm relay 2 output
- 12 - 13 - 14: alarm relay 1 output

**Note:** The earth conductor must not pass through the toroid.  
For single phase applications, only the live and neutral need to be passed through the toroid.

Cabling: for distances > 1 m, use twisted pair cable between the unit and toroid.  
Do not connect the shield to earth.

## References

Auxiliary power supply $U_s$ <sup>(1)</sup>	RESYS M40R Reference
115/230 VAC	4941 3724
400 VAC	4941 3741

(1) Other rating: Please consult us.